

Innovative High-tech Ceramic Components.
Precise. Durable. Wear-resistant.



Founded in Switzerland. Available worldwide.

maxon – a strong global brand

maxon, with headquarters in Sachseln/Central Switzerland, has production sites in Switzerland, Germany, Hungary, South Korea, USA, France, Netherlands and China as well as sales companies in more than 30 countries. Our machines and product lines are developed in-house to guarantee cost-effective manufacturing of our products and enabling us to create custom solutions to fit your specific application needs.

Precision Drive Systems

maxon develops and builds precision drive systems. Our brushless and brushed DC motors with ironless windings are among the best in the world. Flat motors with iron cores complete our modular product portfolio. maxon's modular system includes planetary and spur gearheads, spindle drives, as well as encoders and control electronics.

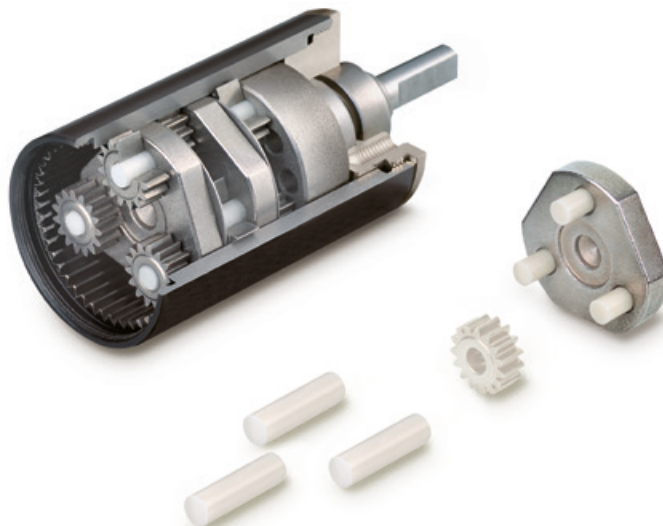

A unique material.

Ceramic can be used where other materials fail.

maxon develops and manufactures customizable CIM (Ceramic Injection Moulding) components in Sexau in the south-west of Germany. Our development and engineering program is based on more than 20 years experience in Powder Injection Moulding (PIM) and we work with the most up-to-date CAD technology and finite element calculation. Thanks to CIM, maxon is well-placed to produce highly complex ceramic components - providing extreme precision and supreme quality.



The advantages of ceramic as a material

- Extremely high wear-resistance and hardness
- Excellent sliding characteristics
- Mechanical strength
- Long service life
- High temperature resistance
- Outstanding insulation properties
- High corrosion and chemical resistance
- Biocompatible
- Low specific weight

Our areas of application

Clock technology

Measurement technology

Audio technology

Industrial automation

Medical technology

Drive technology

ceramic.maxongroup.com

Clock technology

Components for mechanical clockwork



Precise and long-life.

Ceramic components for automatic clockwork

- Extreme precision
- For generations to come
- High degree of wear-resistance
- Dependable serial production
- Completely non-magnetic

The small components of a clock mechanism have to be constructed with the utmost precision to ensure reliability. With ceramic components the intermeshing parts will maintain the same level of precision for generations to come.



Measurement technology

Sensor housing for flow meters

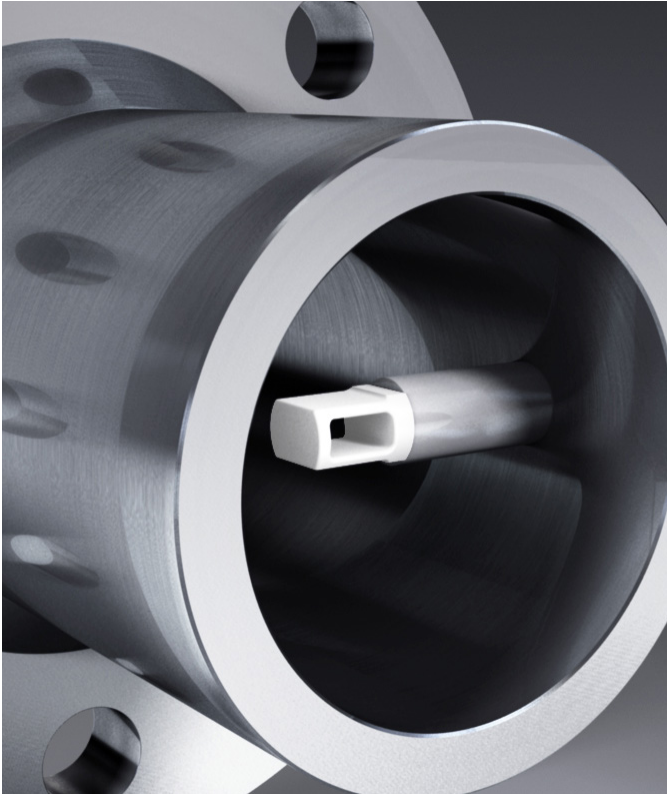

Highly robust in extreme environmental conditions.

Ceramic withstands adverse conditions. When used in sensor housings, it demonstrates resistance to high temperatures, abrasive gas flow dust, and chemically aggressive condensate. Its low thermal conduction protects the electronics inside the sensors. Its passive behavior in electrical and magnetic fields allows electronic sensors to be deployed.

- High resistance to extreme conditions
- Low thermal conduction
- Passive behavior in electrical and magnetic fields
- Avoids maintenance costs and oncosts



Audio technology

Housings for high-tech in-ear headphones

Scratch-resistant ceramic for headphone housings ensures long service life and a pleasant user experience.

Ceramic surfaces impress with their scratch-resistance and surface shine. Its low thermal conduction means ceramic is warm and pleasant to the touch. The continuous development of our forming and polishing processes achieves a very special combination of aesthetics and functionality. Ceramic housings protect the high-quality technology inside and present a high-quality exterior which lasts.



- Perfect surface finish
- Scratch-resistant for a long service life
- Low thermal conduction for pleasant user comfort
- Optimal acoustic properties



Audio technology

Bearings for high-end record players

There are no compromises in the pursuit of the perfect listening experience: All the elements need to work in perfect harmony. Our ceramic components are ideal for innovative customised turntable bearings. The use of ceramics means that challenges such as magnetic fields and precision radial run-out are easily overcome. The demands in the high-end range are extremely high: Extreme precision and the highest quality in materials, manufacture and surface finishes always come first. Smooth working relationships based on trust are paramount in ensuring a first-class high-end product.

Finished parts made from technical ceramics enable precision scanning of record grooves.



- Completely non-magnetic
- Perfect surface finish
- High wear-resistance



Industrial automation

Components for industrial machinery



In industrial automation, ceramic impresses with its hardness, stability, wear-resistance and sliding characteristics.

Machine and plant availability is extremely important in the industrial sector. Ceramic impresses here with its hardness, stability, wear-resistance and outstanding sliding characteristics. A prime example of this is maxon's ceramic spindle with its cgs (ceramic glide surface). Sockets/connectors, guides, axles and shafts are also typical ceramic insert elements. The chemically resistant and non-magnetic material can also be used where other materials reach their limits.

- High wear-resistance
- Extreme level of hardness
- Outstanding surface finish
- Excellent stability



Medical technology

Insulation components for endoscopes

Ceramic insulation components give outstanding results in the field of endoscopy: They are biocompatible and robust.

Medical technology places particularly high demands on the materials used in medical devices (e.g. endoscopes): Only optically perfect, high quality, reliable components make the grade. In addition, materials must also be biocompatible and resistant to bodily fluids.



- Perfect surface finish
- Biocompatible
- Low thermal conduction
- Highly robust

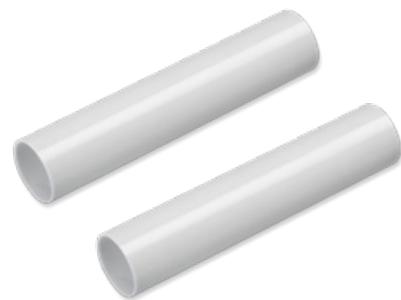

Drive technology

Spindles for extreme conditions

Robust and corrosion-resistant materials are required for use in salt water.



In drive technology, the limitations of traditional materials can become evident, depending on the application involved. So, for example, customised underwater drives require salt water resistant materials. Our ceramic spindles give outstanding service here: They are corrosion-resistant, robust, wear-resistant and at the same time extremely efficient.



The maxon cgs (ceramic glide surface) ceramic spindles

- Work with virtually no slip-stick effect
- Smooth-running
- Extreme hardness
- Extra long service life
- High wear-resistance
- Excellent efficiency

Techniques and Manufacturing Processes

Different processes for the manufacturing of high quality ceramic products achieve optimal outcomes.

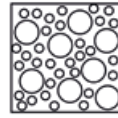
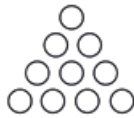

Process	Material	State	Process	Final Process
CIM*-Process	Powder	Feedstock	Injection Moulding	Thermal Debinding & Sintering
Compression Process	Powder		Compression Moulding	Sintering
Additive Manufacturing	Powder	Suspension	LCM*-Process	Thermal Debinding & Sintering

*Ceramic Injection Moulding
*Lithography-based Ceramic Manufacturing

Zirconium oxide ZrO_2

Mechanically high load-bearing

Zirconium oxide is a high-performance industrial ceramic, used particularly in ranges where traditional materials reach their limits.

Special properties of zirconium oxide:

- Excellent wear-resistance and hardness
- Outstanding sliding characteristics
- Excellent mechanical stability
- High degree of temperature resistance
- Superior insulation properties
- High corrosion- and chemical resistance, comprehensive acid- and alkali-resistance
- Modulus of elasticity and heat expansion coefficient similar to steel
- Biocompatible and low in allergens
- Low specific weight

General properties of the material

Bending strength	>800 N/mm ²
E-modulus	2 x 10 ⁵ N/mm ²
Density	≥6,08 g/cm ³
Härte	1350 HV
Hardness Heat expansion coefficient	10 x 10 ⁻⁶ 1/K
Thermal conductivity	2 W/ mK
Electrical resistance	10 ¹⁰ Ωcm

Aluminium oxide Al_2O_3

High thermal load capacity

Aluminium oxide is widely used in electrotechnology for insulation.

Special properties of aluminium oxide:

- Excellent temperature resistance
- Good thermal conductivity
- Median mechanical stability
- Low heat expansion coefficient
- High corrosion- and chemical resistance, extensive acid- and alkali-resistance
- High level hardness
- Low specific weight

General properties of the material

Bending strength	>350 N/mm ²
E-modulus	3,5 x 10 ⁵ N/mm ²
Density	≥3,98 g/cm ³
Härte	2000 HV
Hardness Heat expansion coefficient	≥5 x 10 ⁻⁶ 1/K
Thermal conductivity	25 W/ mK
Electrical resistance	10 ¹⁵ Ωcm

Standard ceramic components

Spindles

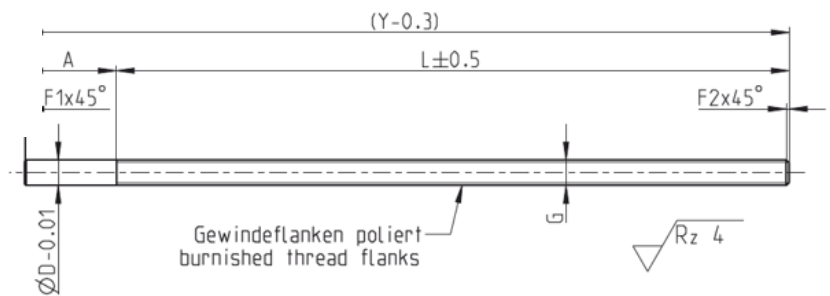

G	Colour	Part No.	D	A max.	L max.	F1	F2	(Y) max.
M2	White	426634	2.0	18	102	0.3	0.3	120
M2.5	White	426707	2.5	18	132	0.3	0.3	150
M3	White	426715	3.0	18	132	0.4	0.4	150
M4	White	426717	4.0	18	132	0.5	0.5	150
M5	White	426730	5.0	18	132	0.6	0.6	150
M6	White	426740	6.0	18	232	0.7	0.7	250
M8	White	426763	8.0	18	232	0.8	0.8	250
M10	White	426783	10.0	18	232	1.0	1.0	250

Also available in black.

Larger diameters and lengths upon request.

Standard ceramic components

Axles

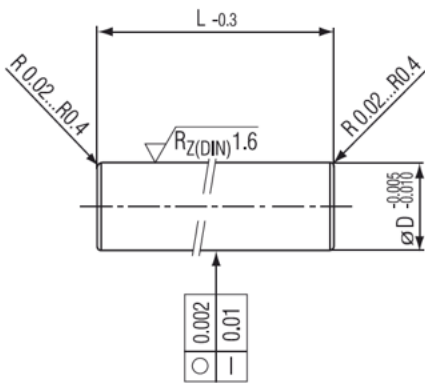

ØD	L = 2.4	L = 6.4	L = 7.4	L = 10.6	L = 13.8	L = 15	L = 35	L = 40	L = 60	L = 70	L = 120
0.8	255899	255900	255901	255902	255903	255904	255905 ⁴⁾	348501 ⁴⁾	348502 ⁵⁾	348503 ⁶⁾	
1.0	255891	255892	255893	255894	255895	255896	255898 ⁴⁾	348498 ⁴⁾	348499 ⁵⁾	348500 ⁶⁾	
1.5	255883	255884	255885	255886	255887	255888	255889 ⁴⁾	255890 ⁴⁾	255792 ⁵⁾	255793 ⁶⁾	
2.0	255872	255873	348693	255875	255876	255877	255879	255880	255881	255882	
2.5	255864	143825 ^{3/7)}	255866	255867	255868	255869	255870	255871	346621	348288	
3.0	255856	255857	255858	255859	255860	255861	255862	255863	346619	346620	
4.0	255845	255846	166875 ^{13/17)}	137962 ^{13/17)}	255849	255850	255851	255853	255854	255791	255787 ⁵⁾
5.0	255833	255834	255835	255836	255837	255838	255839	255840	255841	255842	255843 ⁵⁾
5.5	255818	255819	255820	255786	205063 ^{2/3/17)}	255825	255826	255827	255828	255830	255831 ⁵⁾
6.0	255806	255807	255808	255809	255810	255811	255812	255813	255814	255815	255816 ⁵⁾
8.0	255794	255795	255796	255797	255798	255799	255800	255801	255802	255803	255804 ⁵⁾

- 1) Diameter tolerance variance: -0.008/-0.013
- 2) Diameter tolerance variance: -0.013/-0.018
- 3) Edge chamfer R 0.3 ± 0.1
- 4) Straightness tolerance variance: 0.02 mm
- 5) Straightness tolerance variance: 0.03 mm
- 6) Straightness tolerance variance: 0.04 mm
- 7) Roundness tolerance variance: 0.003 mm

A global network

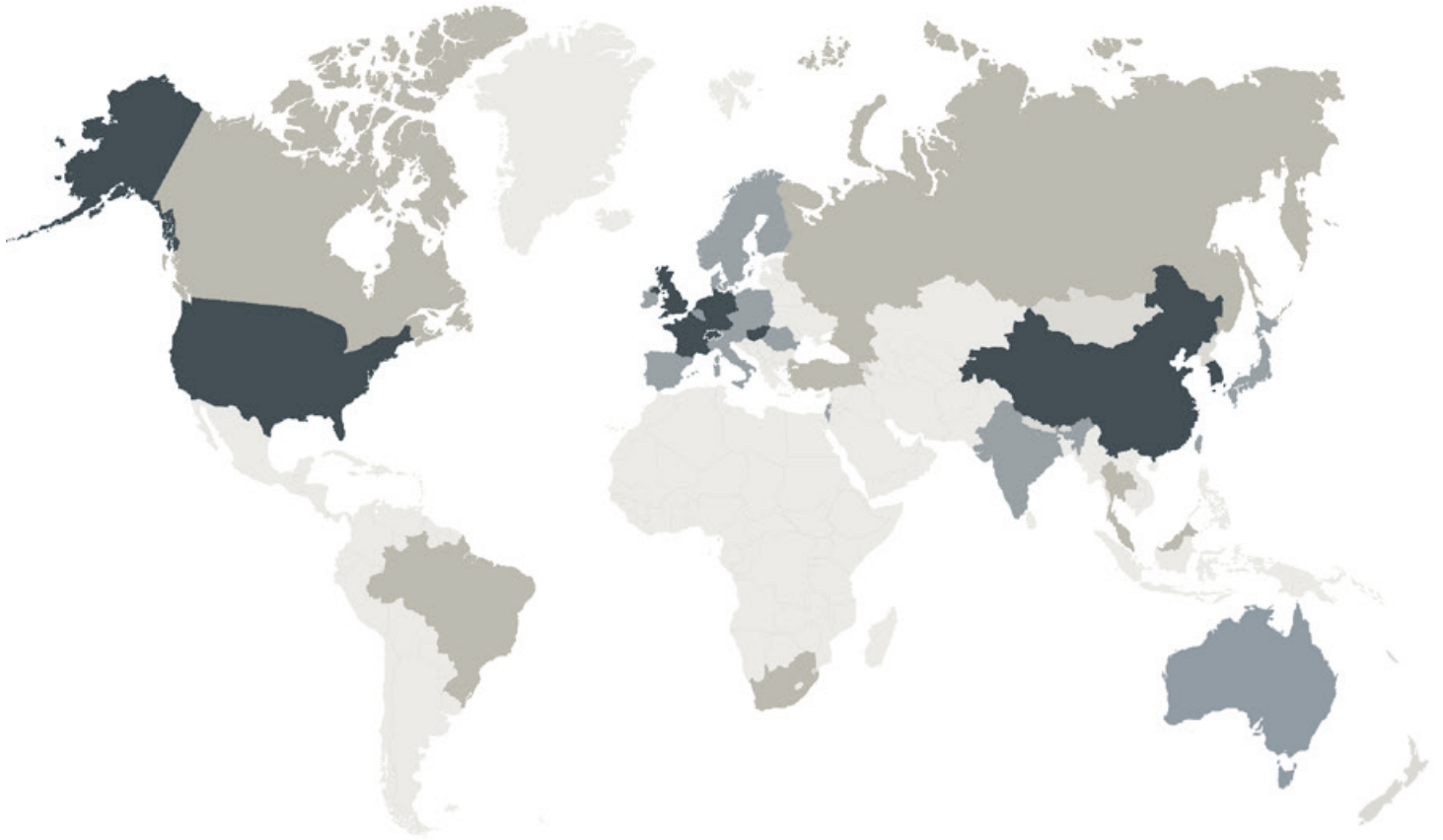

maxon Manufacturing Companies

Switzerland (Headquarters)	South Korea	USA
Germany	France	China
Hungary	the Netherlands	Great Britain

maxon Sales Companies

Australia	Hungary	Singapore
Austria	India	Slovakia
Benelux	Ireland	Slovenia
China	Israel	South Korea
Czechia	Italy	Spain
Denmark	Japan	Sweden
Finland	Norway	Switzerland
France	Poland	Taiwan
Germany	Portugal	USA
Great Britain	Romania	

maxon Sales Agents

Brasil	Malaysia	Thailand
Canada	Russia	Turkey
Hong Kong	South Africa	

Contact us:
ceramic.de@maxongroup.com

