

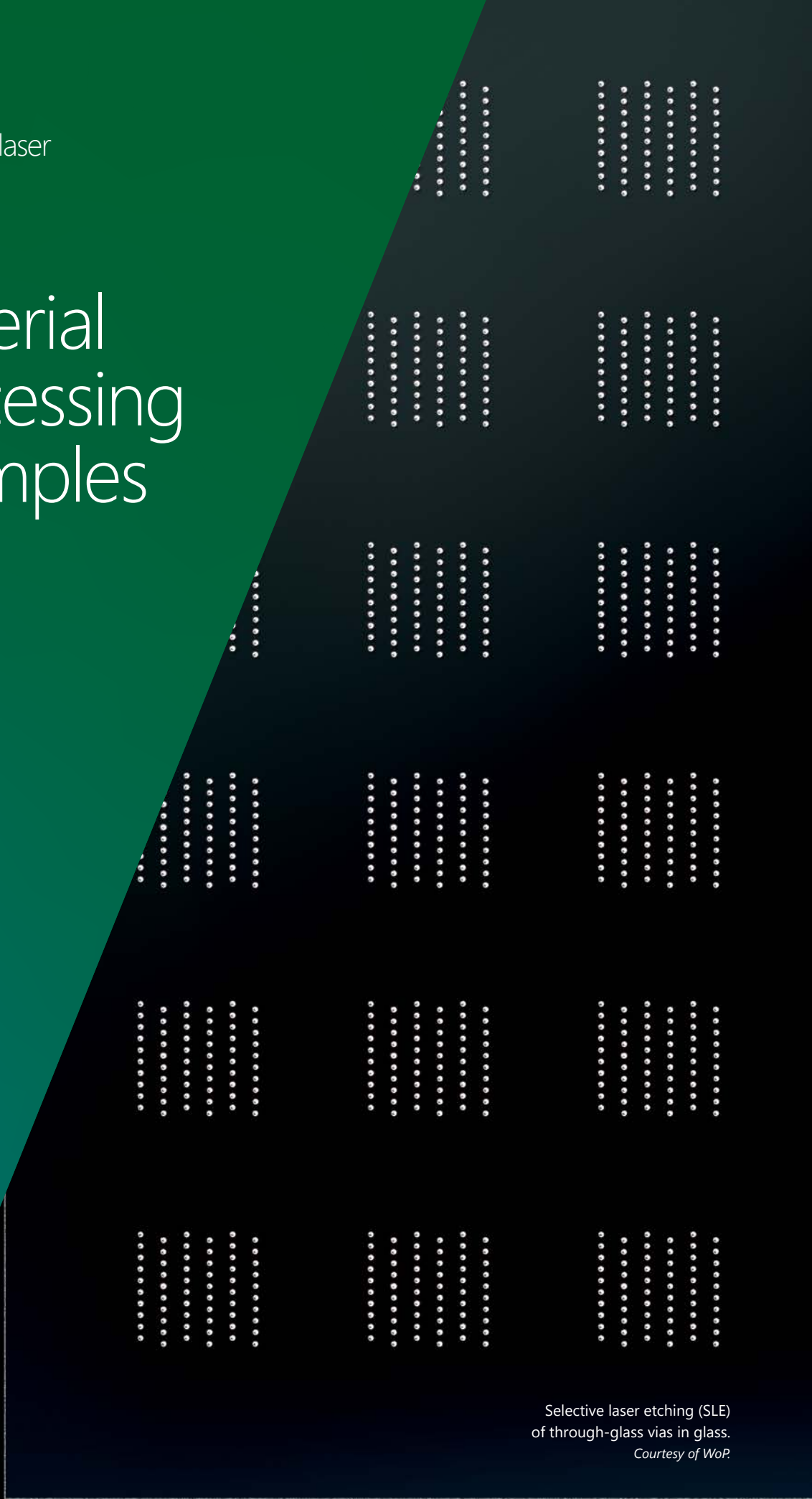

Made with
FemtoLux laser

Material processing examples



Selective laser etching (SLE)
of through-glass vias in glass.
Courtesy of WoP.

Material Processing Examples

Glass

Through glass vias (TGVs) fabrication

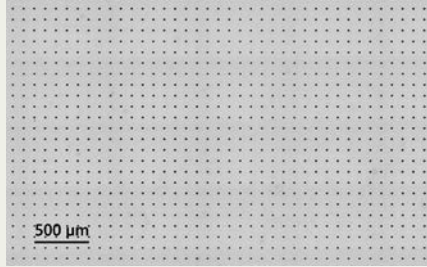

GHz burst assisted percussion drilling of high aspect ratio holes in EXG glass.
Courtesy of Akoneer.

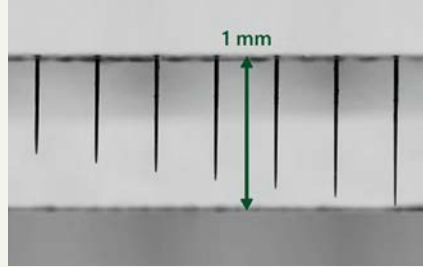

GHz burst assisted percussion drilling of high aspect ratio holes in EXG glass.
Courtesy of Akoneer.

TAILORED FOR SEMICONDUCTOR INDUSTRY

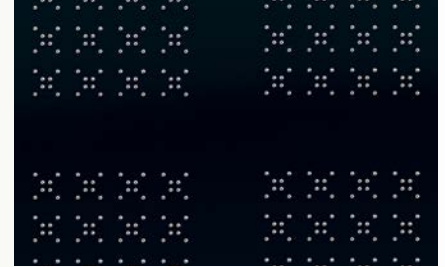

Selective laser etching (SLE) of through-glass vias in glass.
Courtesy of WoP.

Laser-based Bessel beam scribing

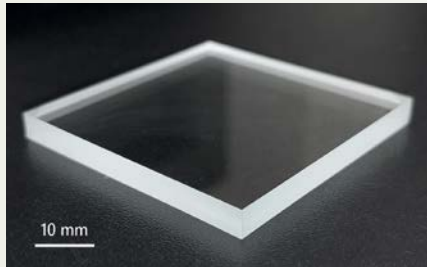

Laser-based Bessel beam scribing of 4.8 mm soda-lime glass.
Courtesy of FTMC.



Scribed 4.8 mm soda-lime edge view.
Courtesy of FTMC.

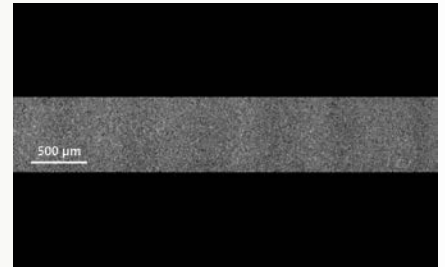

Scribed 1 mm soda-lime side wall view.
Courtesy of FTMC.

Bottom-up milling of glass

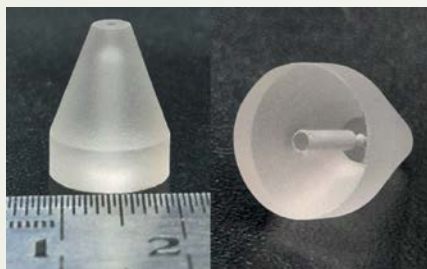

Glass nozzle fabrication by using multi-step bottom-up milling.
Courtesy of FTMC.

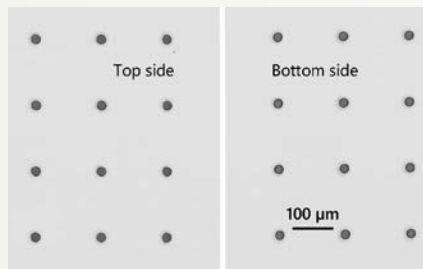

Bottom-up milling of 100 μm diameter taper-free channels in glass.
Courtesy of FTMC.

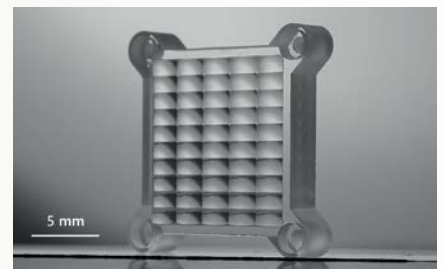

Cutting custom micro-lens array substrate from thick fused-silica glass.
Courtesy of FTMC.

Thin glass cutting

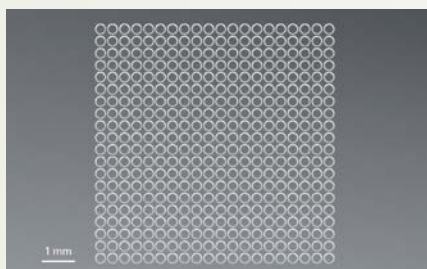

300 μm hole drilling in thin borosilicate glass.
Courtesy of FTMC.

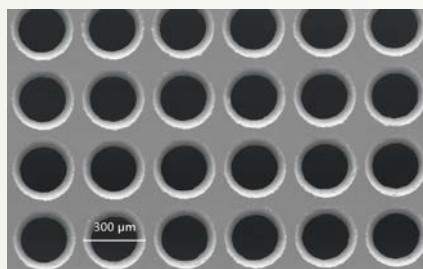

SEM image of 300 μm holes in borosilicate glass.
Courtesy of FTMC.



Thin fused-silica cutting.
Courtesy of FTMC.

Material Processing Examples

Metal

Nitinol stent cutting

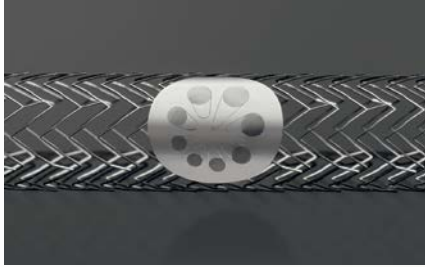

Nitinol stent cutting.
Courtesy of Vactronix Scientific.

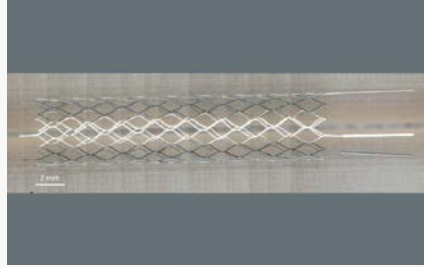

Nitinol stent cutting.
Courtesy of JEM Laser.

TAILORED FOR MEDICAL INDUSTRY

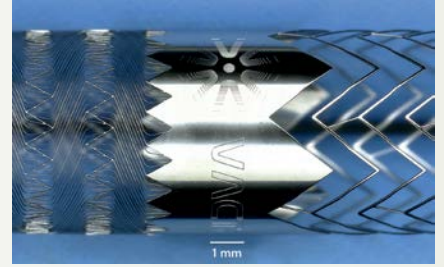

Nitinol stent cutting.
Courtesy of Vactronix Scientific.

Metal cutting

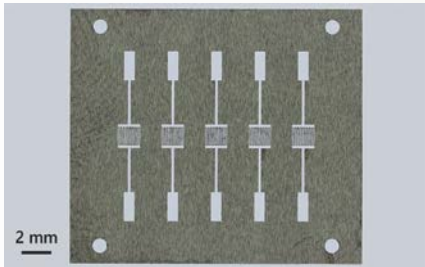

50 µm thickness stainless steel cutting.
Courtesy of Laser Micromachining Ltd.

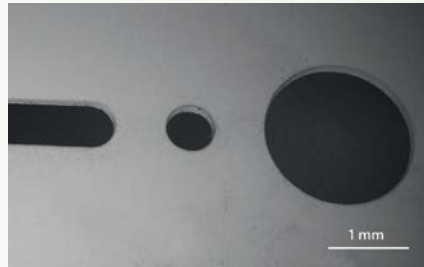

125 µm thickness tantalum cutting.
Courtesy of Laser Micromachining Ltd.



Kovar cutting.
Courtesy of Laser Micromachining Ltd.

Surface structuring

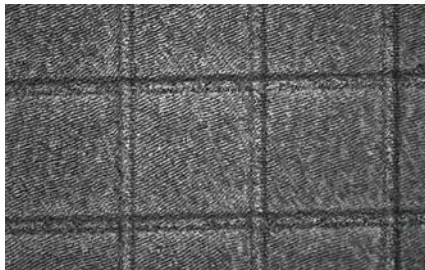

Grid surface texturing with LIPSS of nitinol.
Courtesy of UNIMORE

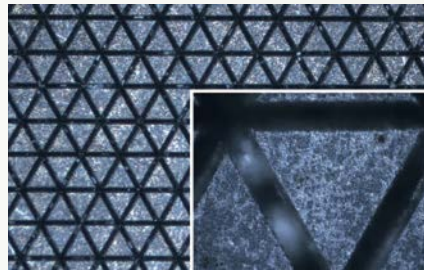

Triangular surface texturing with LIPSS of stainless steel.
Courtesy of UNIMORE.



Textured aluminum molds.
Courtesy of FTMC.

Marking



Black marking of tweezers.
Courtesy of FTMC.



Color marking of stainless steel.
Courtesy of Akoneer.

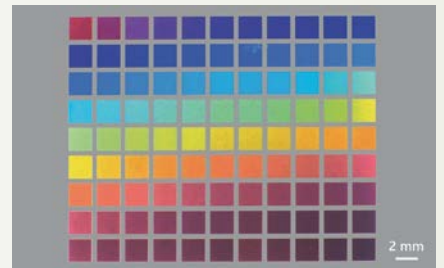

Color marking of titanium film.
Courtesy of Akoneer.

Polymer

Cutting of polymer

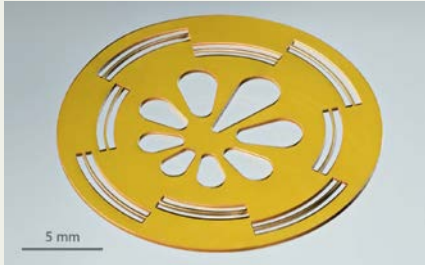

Polyimide cutting.
Courtesy of FTMC.

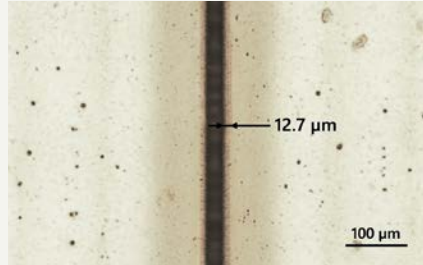

Polyimide cutting with 515 nm, indicated heat affected zone.
Courtesy of FTMC.

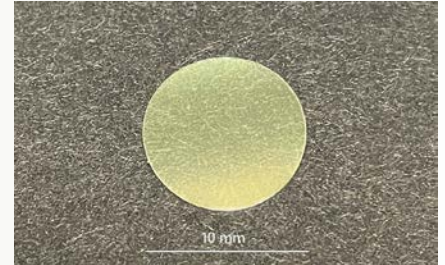

10 mm circle cut out of thin polymer film.
Courtesy of FTMC.

Photopolymerization

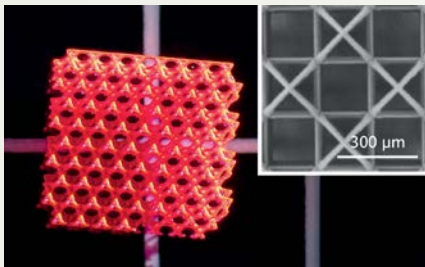

Photopolymerization.
Courtesy of Femtika.

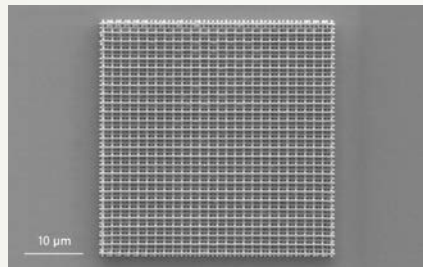

SEM image of photopolymerization sample.
Courtesy of WOP.

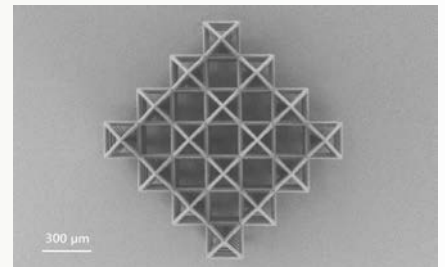

SEM image of photopolymerization sample.
Courtesy of Femtika.

SSAIL

TAILORED FOR SEMICONDUCTOR INDUSTRY

SSAIL is a laser-based technology for **directly writing electronic circuits onto dielectric materials**. The process modifies the dielectric surface, followed by electroless metal plating to form conductive traces.

SSAIL enables trace widths down to **1 μm** and is compatible with a wide range of materials, including **PC/ABS, PMMA, PET, FR-4, Al₂O₃, ceramics, fused silica, and silicon**, making it well suited for semiconductor and advanced electronics applications.

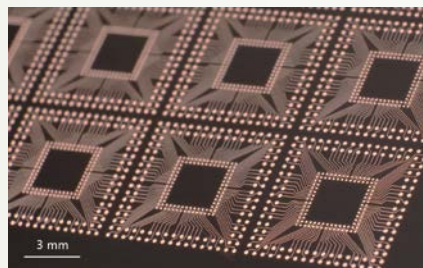

SSAIL technology on PI.
Courtesy of Akoneer

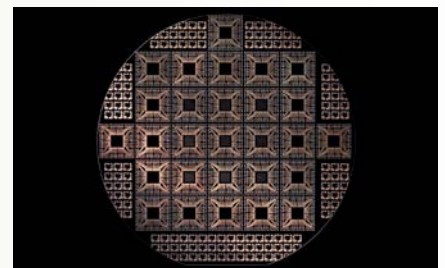

SSAIL technology on glass wafer.
Courtesy of Akoneer



SSAIL technology on PA4T.
Courtesy of Akoneer.

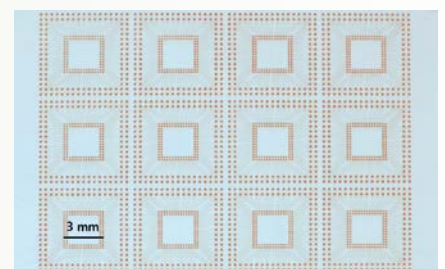

SSAIL technology on glass.
Courtesy of Akoneer.

Other materials

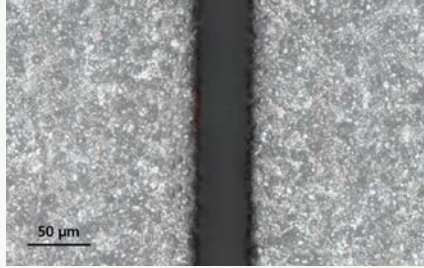

50 µm depth groove formation in ceramic.
Courtesy of FTMC.

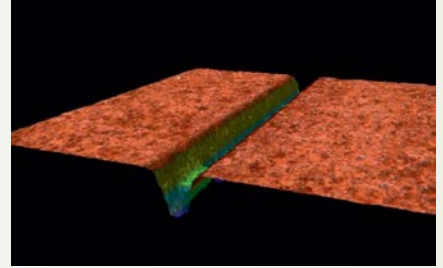

Optical 3D profilometer image of formed groove.
Courtesy of FTMC.

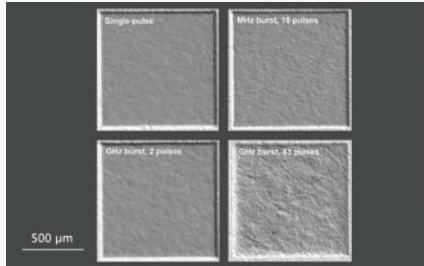

Optical 3D profilometer image of milled alumina squares in different operational modes.

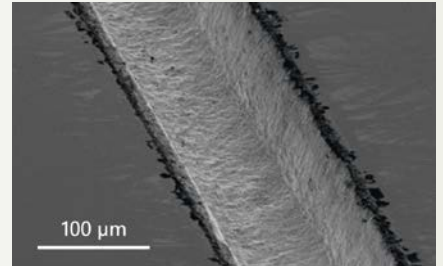

Groove formation in GaAs in water environment.
Courtesy of FTMC.

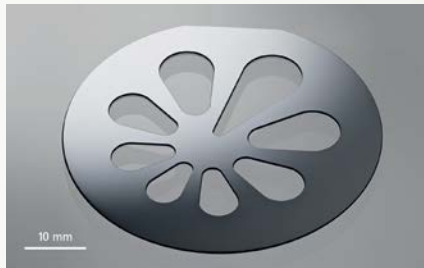

Cutting of FZ-Si wafer.
Courtesy of FTMC.



SEM image of processed FZ-Si wafer edge.
Courtesy of FTMC.

Need a feasibility test for your samples?

Take advantage of EKSPILA's extensive global partner network. Material processing workshops around the world, supported by highly qualified engineers, enable testing of virtually any process on a wide range of materials. Backed by a strong scientific foundation, we offer comprehensive capabilities from initial sample testing to full process development.

Please send your requests to sales@ekspla.com.

SSAIL technology on glass wafer.
Courtesy of Akoneer.

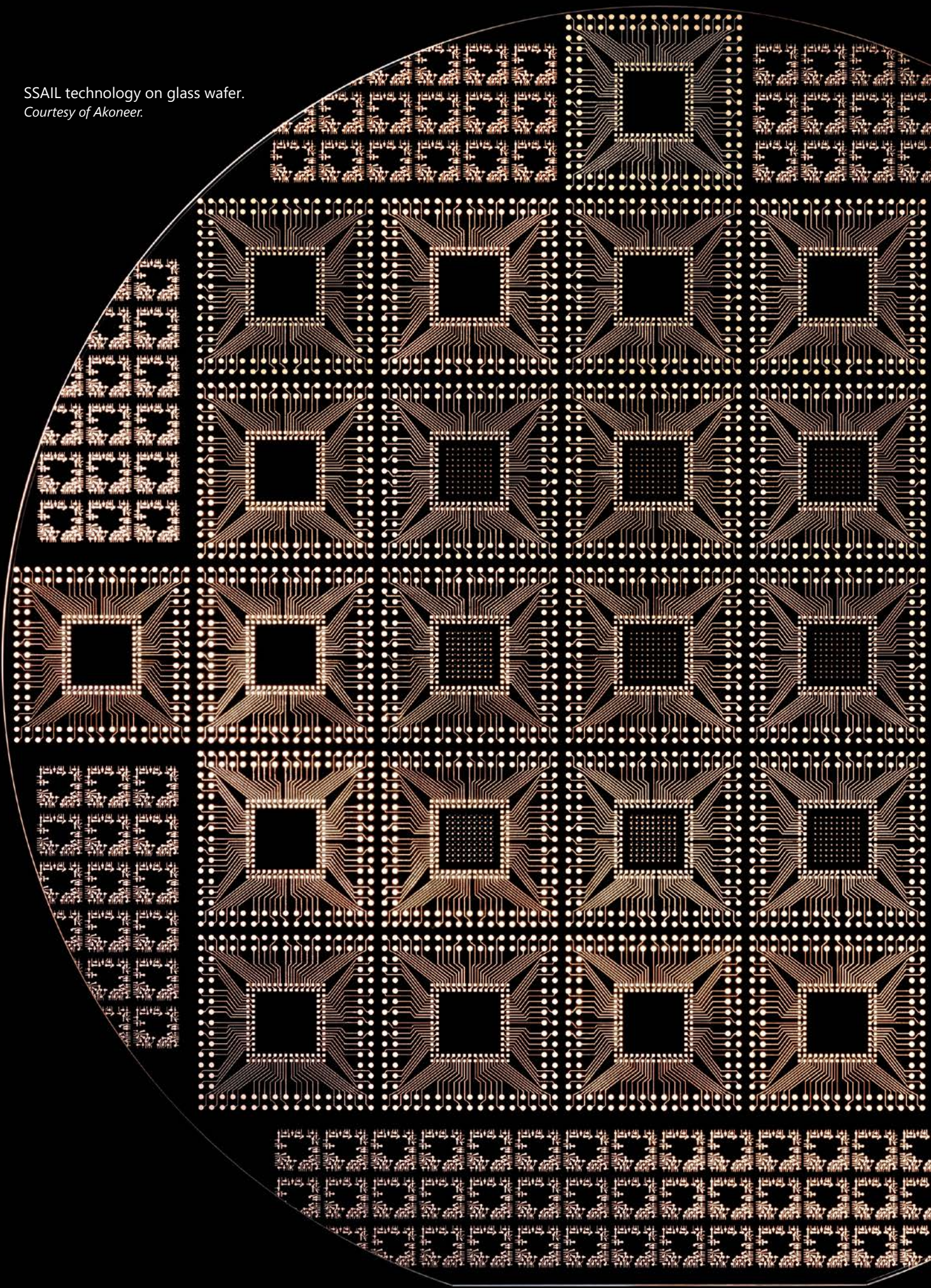

fs

Industrial
Femtosecond
Lasers

FemtoLux

Reliability Redefined



2024

A reliable &
versatile tool for
micromachining

/ Micromachining for
advanced packaging solutions

/ Medical device fabrication

/ Glass micromachining
and intra-volume structuring

/ Micromachining of
different metals and polymers

/ Solutions for
microelectronics fabrication



Industrial Dry Cooled Femtosecond Laser

FemtoLux

Designed from the get-go for maximum reliability, seamless integration and non-stop 24/7/365 zero maintenance operation with innovative "dry" cooling.

The FemtoLux femtosecond laser has a tunable pulse duration from <400 fs to 1 ps and can operate in a broad AOM controlled range of pulse repetition rates from a single shot to 4 MHz.

The maximum pulse energy is 1 mJ operating with single pulses and can reach even up to 2 mJ in burst mode, ensuring higher ablation rates and processing throughput for different materials.

The FemtoLux beam parameters will meet the requirements of the most demanding materials and micro-machining applications.

Innovative laser control electronics ensure simple control of the FemtoLux laser by external controllers that could run on different platforms, be it Windows, Linux or others using REST API commands.

This makes easy integration and reduces the time and human resources required to integrate this laser into any laser micromachining equipment.

Seamless User Experience

Easy integration – remote control using REST API via RS232 and LAN.

Reduced integration time – demo electronics is available for laser control programming in advance.

Easy and quick installation – no water, fully disconnectable laser head. Can be installed by the end-user.

Easy troubleshooting – integrated detectors and constant system status logging.

No periodic maintenance required.

Zero
maintenance

"Dry"
cooling

Features

Typical max output power
50 W at 1030 nm,
20 W at 515 nm,
10 W at 343 nm

Typical max output energies
> 300 µJ at 1030 nm,
> 50 µJ at 515 nm,
> 25 µJ at 343 nm

Up to 1 mJ for FemtoLux HE

MHz, GHz, MHz+GHz burst
modes

up to 2 mJ in a burst mode

< 400 fs – 1 ps

Pulse duration extension
up to 1 ns

Single shot – up to 4 MHz
(AOM controlled)

Pulse-on-demand (PoD),
with jitter as low as 20 ns
(peak-to-peak)

<0.5% RMS power long term
stability over 100 hours

$M^2 < 1.2$

Beam ellipticity > 0.85



Learn more
about FemtoLux
www.ekspla.com

“Dry” Cooling

Direct Refrigerant Cooling (DRC)

Direct refrigerant cooling is industry-proven thermal-management approach with a long history in everyday technologies such as domestic refrigeration and automotive climate control. Unlike conventional liquid cooling, it operates **without pumped water circuits**, relying instead on direct refrigerant-based heat transfer.

How DRC Works

At its core, DRC eliminates the inherent reliability limitations of water-based cooling loops. Rather than circulating liquid coolant through pumps, hoses, and reservoirs, refrigerant is delivered **directly to a cold plate** that is in contact to the laser head.

The FemtoLux cooling architecture comprises four key elements: a compressor, condenser, expansion valve, and evaporator. High-pressure refrigerant is circulating through the expansion valve, which is mounted directly on the cooling plate. As the refrigerant expands, it enters the plate as a low-temperature, low-pressure liquid. While flowing through the plate, it absorbs heat from the laser head and undergoes a controlled phase change into vapor. This vapor is then compressed and routed through the condenser, where heat is released to the surrounding environment and the refrigerant returns to liquid form.

The closed refrigerant circuit provides exceptional integration flexibility. The compressor and condenser are housed within the power supply unit, while the cooling plate and expansion valve are connected via **three-meter armored flexible lines**. This arrangement allows the laser head to be installed inside material processing workstations or mounted on moving stages. A variable-speed compressor continuously adjusts cooling output to match real-time thermal demand, preventing temperature fluctuations that can affect laser performance.

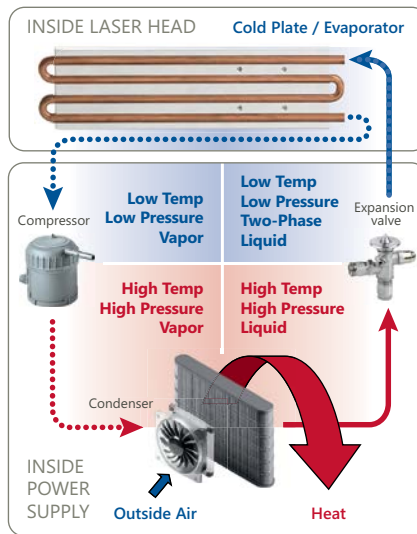

DRC layout and compressor picture.
Courtesy of Aspen Systems Inc.



Learn more about **Dry cooling technology** in this article published in **Photonics Spectra** magazine

Benefits

Military-grade reliability
>90 000 hours MTBF

No maintenance

50 % lower power consumption compared to water cooling equipment

Easy and simple installation

Increased stability due to precise temperature control across a wide range of operating conditions

“Greenest” cooling technology



A cooling plate is attached to the laser on one side of the design (above). On the other, a compressor with auxiliary electronics is installed into the laser power supply unit.

Straightforward Installation and Maintenance-Free Operation



For ease of integration, the cooling plate can be detached from the laser head during system assembly. Flexible refrigerant lines allow the laser head to be positioned independently of the compressor unit, simplifying mechanical integration.

Because the refrigerant loop is **hermetically sealed at the factory**, routine maintenance associated with water-based systems—such as refilling, filter changes, or system flushing—is eliminated entirely.

For system integrators, dry cooling represents a substantial step forward. By removing the constraints of water and air cooling, DRC simplifies system design while enabling compact layouts. The streamlined cold-plate interface reduces installation complexity, and the compact power supply unit supports straightforward system integration.

The absence of pumps and reservoirs keeps system dimensions small. The compressor is up to **10 times smaller and lighter** than conventional designs. The FemtoLux laser head with integrated cooling plate weighs **32 kg**, while the power supply unit—including compressor and condenser—adds only **15 kg**.

Precision Temperature Control and Energy Efficiency

Direct refrigerant cooling delivers **approximately 50% higher energy efficiency** than water-cooled solutions, while maintaining highly uniform cold-plate temperatures through phase-change heat transfer. Comparative testing has shown that DRC systems consume roughly **half the electrical power** of traditional liquid chillers under identical operating conditions.

Thermal regulation is both precise and responsive. The variable-speed compressor adapts continuously to changing heat loads, maintaining laser operating temperature within **±0.1 °C** across the full performance range.

FemtoLux lasers use a **low-global-warming-potential (GWP) refrigerant** approved for laboratory operation and transport. Compared to alternative cooling methods, DRC consumes about half the power of chiller-based systems and up to **eight times less** than thermoelectric cooling solutions. Unlike air cooling, DRC can operate **below ambient temperature** or hold a tightly defined thermal setpoint.

Proven Reliability from Military to Industry

This cooling approach has been deployed by **Aspen Systems** for more than 15 years in demanding defense applications where size, weight, efficiency, and reliability are critical. These include military communications systems, high-power directed-energy platforms on armored vehicles, transport enclosures, ships, and helicopters.



Aspen refrigeration systems, as used in military applications.
Courtesy of Aspen Systems Inc.

The technology demonstrates a mean time between failures (MTBF) exceeding **90,000 hours**, enabling continuous operation for more than a decade. In long-term testing, FemtoLux lasers have demonstrated stable operation beyond **25,000 hours**. Compressor service life typically surpasses that of water-chiller pumps by a factor of **three to five**, further enhancing system reliability.

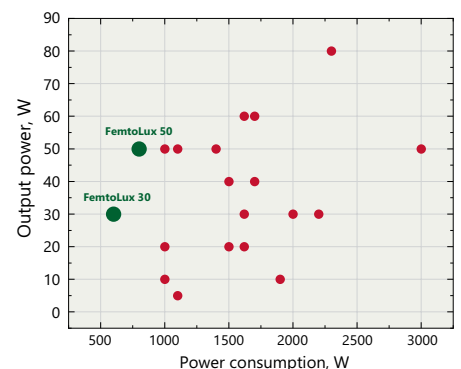

FemtoLux 30 and 50 power consumption and output power comparison versus other ultrafast lasers manufacturers

GHz Burst Option

Patent-Pending Method
for Ultra-High Rate Bursts

Short GHz burst

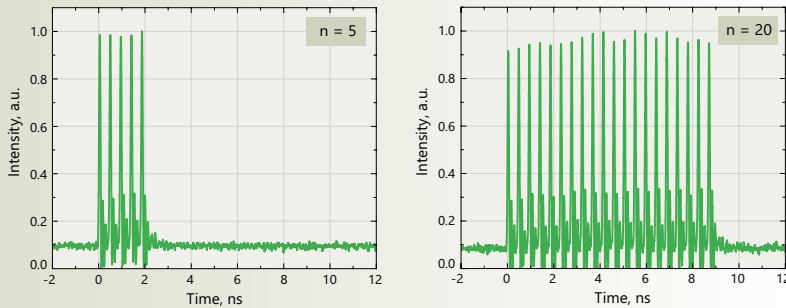

Fig 1-2. Measured 2.2 GHz intra-burst PRR burst of pulses containing a different number of pulses of equal amplitudes at 31.5 W average output power

Long GHz burst

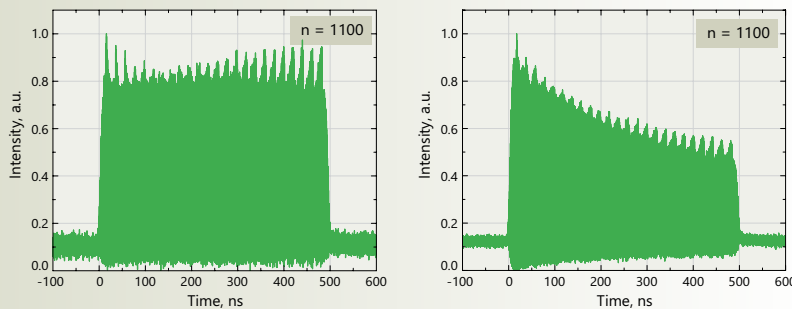

Fig 3. Measured 2.2 GHz pre-shaped bursts of 1100 pulses at 233 kHz burst repetition rate for the desired rectangular-like burst shape

Fig 4. Measured 2.2 GHz non-pre-shaped bursts of 1100 pulses at 233 kHz burst repetition rate

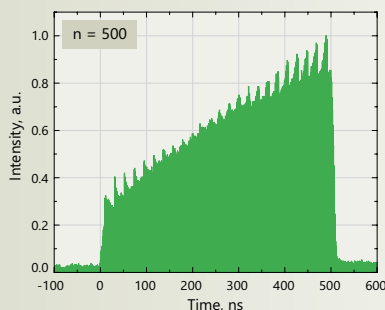

Fig 5. Measured 2.2 GHz pre-shaped bursts of 500 pulses at 233 kHz burst repetition rate for the desired rising burst shape

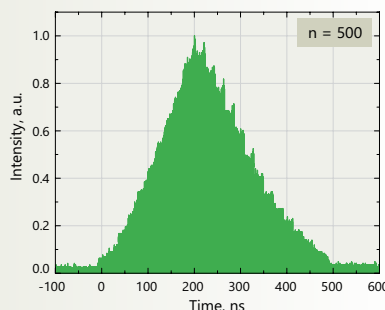

Fig 6. Measured 2.2 GHz pre-shaped bursts of 500 pulses at 233 kHz burst repetition rate for the desired triangle burst shape

Benefits

The Femtolux laser can operate in the **single-pulse** mode, **MHz burst** mode, **GHz burst** mode, and **MHz + GHz burst** mode.

The burst formation technique based on the use of the AFL is a very versatile method as it allows to overcome many limitations encountered by other fiber- and/or solid-state-based techniques.

Any desired intra-burst PRR can be achieved independently from the initial PRR of the master oscillator

Identical pulse separation inside the GHz bursts is maintained

Short- and long-burst formation modes can be provided.

/ A short burst is up to about 10 ns burst width (from 2 to tens of pulses in the GHz burst).

/ A long burst is from ~20 ns up to a few hundred ns in burst width (from tens to thousands of pulses in the GHz burst)

MHz+GHz burst mode

An adjustable amplitude envelope of the GHz bursts is provided

No pre/post pulses in GHz burst. Pure GHz bursts

Ultrashort pulse duration is maintained inside the bursts

A new versatile patent-pending method to form ultra-high repetition rate bursts of ultrashort laser pulses.

The developed method is based on the use of an all-in-fiber active fiber loop (AFL). A detailed description of the invention can be found on:

[1] Andrejus Michailovas, and Tadas Bartulevičius. 2021 Int. patent application published under the Patent Cooperation Treaty (PCT) WO2021059003A1.

[2] Tadas Bartulevičius, Mykolas Lipnickas, Virginija Petrauskienė, Karolis Madeikis, and Andrejus Michailovas, (2022), "30 W-average-power femtosecond NIR laser operating in a flexible GHz-burst-regime," Opt. Express 30, 36849-36862.

Principle of AFL Technology

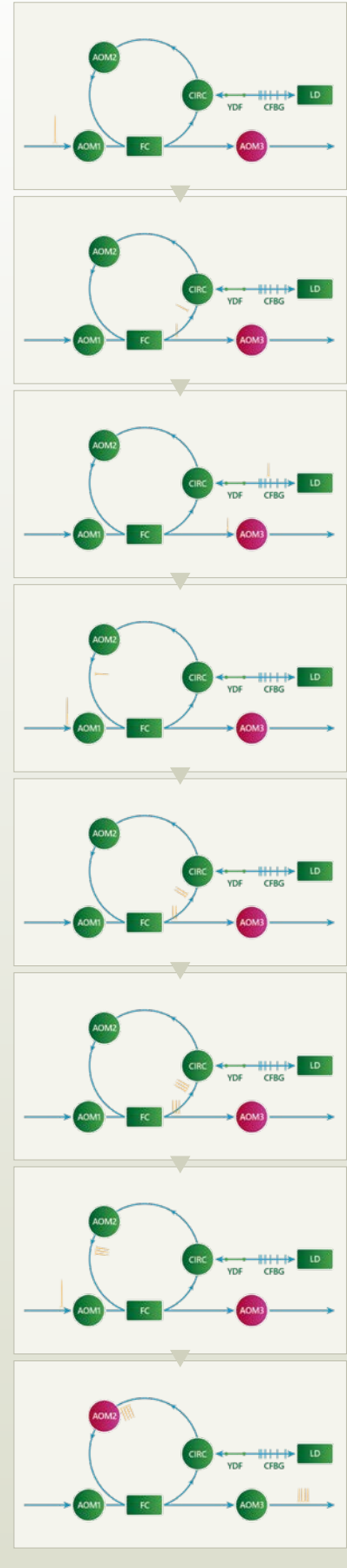

MHz + GHz burst mode

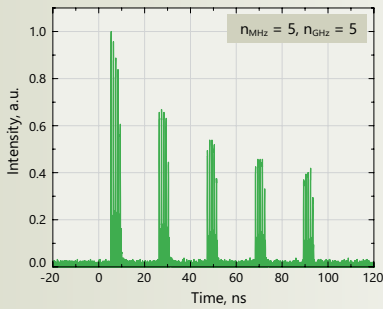

Fig 7. Measured 5 bursts of 50 MHz burst repetition rate containing 5 pulses of 2.5 GHz intra-burst PRR

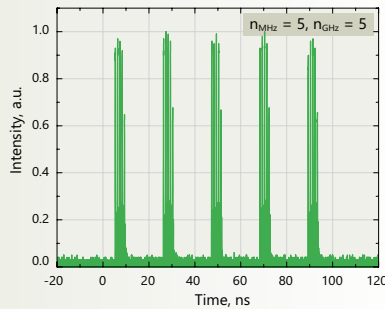

Fig 8. Measured rectangular shape 5 bursts of 50 MHz burst repetition rate containing 5 pulses of 2.5 GHz intra-burst PRR

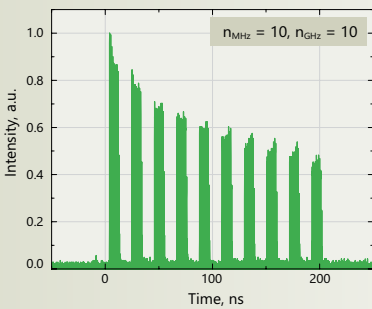

Fig 9. Measured 10 bursts of 50 MHz burst repetition rate containing 10 pulses of 2.5 GHz intra-burst PRR

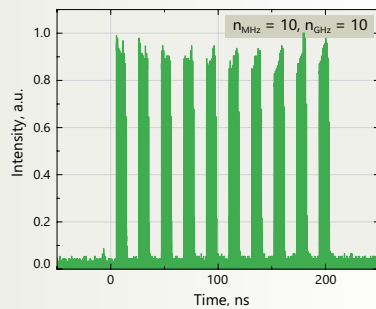

Fig 10. Measured rectangular shape 10 bursts of 50 MHz burst repetition rate containing 10 pulses of 2.5 GHz intra-burst PRR

See video showing principle of AFL technology



Pulse-on-Demand (PoD)

Traditional laser triggering techniques struggle to maintain equally spaced pulses at high speeds (Fig.1, 2). Pulse-on-demand feature tackles this challenge and enables high-speed micromachining (Fig. 3).

Time based laser triggering

Fig 1. Complex shape scanned with time based laser triggering mode with a pulse repetition of 200 kHz and scanning speed of 6 m/s. The scanning started from the top right to the bottom right area. Overlapping pulses result in an overheated area.

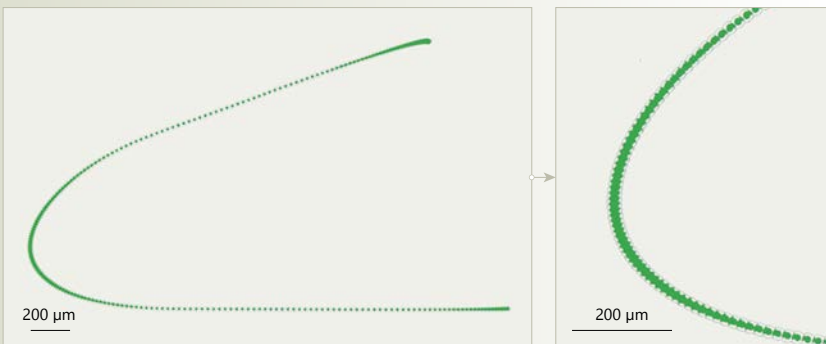

Position based laser triggering

Fig 2. Complex shape scanned with position based laser triggering mode with a pitch of 30 µm and scanning speed of 6 m/s. The scanning started from the top right to the bottom right area. Jitter of tens of µs results in random pulse spacing.

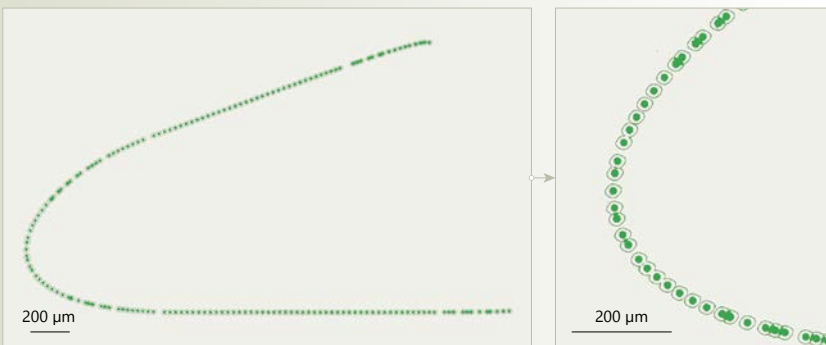

Pulse-on-demand (PoD)

Fig 3. Complex shape scanned with pulse-on-demand (PoD) and position based laser triggering mode with a pitch of 30 µm and scanning speed of 6 m/s. The scanning started from the top right to the bottom right area. PoD feature preserves equidistant pulse spacing at high speeds.

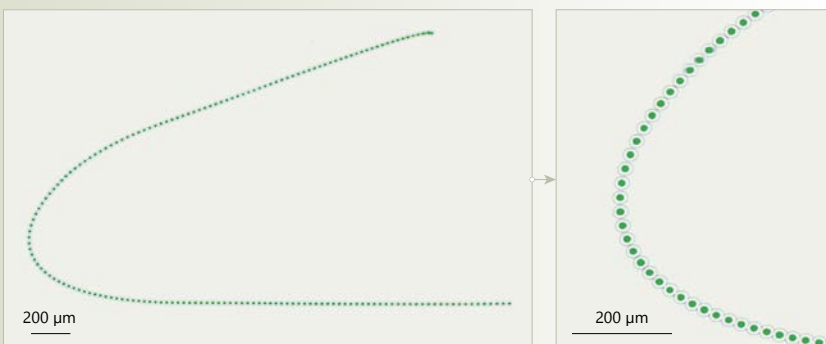

Benefits

Jitter lower than 20 ns ensures consistent and equidistant pulse spacing for high-speed micromachining

Adjustable repetition rate for processing complex geometries

Faster processing speeds, increased productivity

PoD feature enables the laser to fire a pulse only when required, rather than at a constant rate, enabling precise control over the laser's output and resulting in higher efficiency, accuracy and quality.

This capability is especially valuable in various micromachining applications where a high processing speed, constant energy, and accuracy are essential. To follow complex curvature at high speed and to maintain equidistant spacing it is necessary to ensure that the repetition rate of the pulses is adjusted. To achieve these requirements, it is necessary to ensure that the repetition rate of the pulses is adjusted to follow complex curvature at high speed and to maintain equidistant spacing. One may try to use position based laser triggering but, due to laser system limitations, the jitter will be from several µs to tens of µs, which will result in random spacing of the pulses. On the other hand, the usage of time based laser triggering results in overheat areas, due to excessive overlap of pulses. The FemtoLux laser has the pulse-on-demand feature with jitter as low as 20 ns (peak-to-peak), and it can therefore tackle all the challenges and maximize process efficiency, precision and quality at high speed.

Model	FemtoLux 30	FemtoLux 50	FemtoLux HE
Main specifications			
Central wavelength	1030 nm		
Laser pulse repetition rate (PRR) ²⁾	200 kHz – 2 MHz, 4 MHz optional	100 kHz – 2 MHz, 4 MHz optional	10 kHz – 1 MHz
Pulse picker PRR	Laser PRR / N, N=1, 2, 3, ... , 65000; single shot		
Maximal average output power ³⁾	≥ 30 W	≥ 45 W (typical 50 W)	≥ 30 W
Pulse energy ⁴⁾	≥ 100 μJ, 300 μJ optional	≥ 250 μJ (typical 300 μJ)	1 mJ
Power long term stability (Std. dev.) ⁵⁾	< 0.5 %		
Pulse energy stability (Std. dev.) ⁶⁾	< 1 %		
Pulse duration (FWHM) @ 1 MHz ⁷⁾	< 400 fs – 1 ps		
Number of pulses in MHz burst ⁸⁾	2 – 10		
Total energy in burst mode ⁹⁾	> 450 μJ	> 750 μJ	2 mJ
Beam quality	M ² < 1.2 (typical < 1.1)		M ² < 1.3
Beam ellipticity, far field	> 0.85 (typical ≥ 0.9)		
Beam divergence (full angle)	< 1 mrad		
Beam pointing thermal stability	< 20 μrad/°C		
Beam diameter (1/e ²)	2.5 ± 0.4 mm @ 65 cm		
Polarization	vertical		
Synchronization mode	internal / external		
Pulse output control	frequency divider, pulse picker, burst mode, packet triggering, power attenuation, pulse-on-demand		
Control interfaces	RS232 / LAN		
Length of the umbilical cord	3 m, detachable		
Laser head cooling type	dry (direct refrigerant cooling through detachable cooling plate), water cooling optional		
Physical characteristics			
Laser head (W × L × H)	434 × 569 × 150 mm		
Power supply unit (W × L × H)	483 × 534 × 184 mm		
Operating requirements			
Mains requirements	100 – 240 V AC, single phase, 50/60 Hz		
Maximal power rating	1000 W		
Operating ambient temperature	18 – 27 °C		
Relative humidity	10–80 % (non-condensing)		
Air contamination level	ISO 9 (room air) or better		
<p>¹⁾ Due to continuous improvement, all specifications are subject to change without notice. Parameters marked typical are not specifications. They are indications of typical performance and will vary with each unit we manufacture. All parameters are specified for a shortest pulse duration. Unless stated otherwise, all specifications are measured at 1030 nm and for basic system without options.</p> <p>²⁾ When frequency divider is set to transmit every pulse. Fully controllable by integrated AOM.</p> <p>³⁾ At 1 MHz. Please see graphs for power vs laser pulse repetition rate of FemtoLux series lasers.</p> <p>⁴⁾ For FemtoLux 30 maximal pulse energy 300 μJ at 50 kHz. Standard energy 100 μJ at 200 kHz.</p> <p>⁵⁾ Over 100 h after warm-up under constant environmental conditions.</p> <p>⁶⁾ Under constant environmental conditions.</p> <p>⁷⁾ Please see graph for typical pulse duration for different repetition rates.</p> <p>⁸⁾ Oscillator frequency ~50 MHz, ~20 ns separation between pulses.</p> <p>⁹⁾ For MHz burst mode or MHz+GHz burst mode at 50 kHz PRR. For Femtolux HE at 10 kHz.</p>			

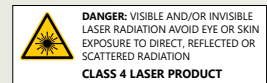

Harmonics modules

Central wavelength	515 nm	343 nm
Main specifications ¹⁾		
Pulse energy ²⁾	50 μ J	30 μ J
Average power	up to 25 W	up to 10 W
Beam quality	$M^2 < 1.2$	$M^2 < 1.3$
Beam ellipticity, far field	> 0.85	
Beam divergence (full angle)	< 0.7 mrad	< 0.5 mrad
Beam diameter ($1/e^2$)	2.2 ± 0.4 mm @ 30 cm	2.4 ± 0.4 mm @ 30 cm
Physical characteristics		
Laser head with harmonic module (W x L x H)	434 x 747 x 158 mm	
¹⁾ Harmonics are optimized at shortest pulse duration and 100 μ J pulse energy. For optimization at different pulse duration or energy, please inquire sales@ekspla.com. ²⁾ Please see graphs for power vs laser pulse repetition rate graphs of FemtoLux series lasers.		

GHz burst option

Main specifications		
Laser Pulse Repetition Rate (PRR)	up to 500 kHz	
Intra-burst pulse repetition rate ¹⁾	2 ± 0.25 GHz	
GHz burst mode	short	long
GHz burst length	0.5 – 10 ns	20 – 500 ns
Number of pulses ²⁾	2 – 20	40 – 1000
Shape	square, rising, falling	falling, pre-shaped ³⁾
MHz + GHz burst mode		
Number of pulses in MHz burst	2 – 10	
Number of pulses in GHz burst ²⁾	2 – 20	
¹⁾ Custom intra-pulse PRR is available upon a request. ²⁾ Depends on the intra-pulse PRR. ³⁾ For more information, please inquire sales@ekspla.com.		



FemtoLux with harmonics module and power supply

Performance of FemtoLux 50

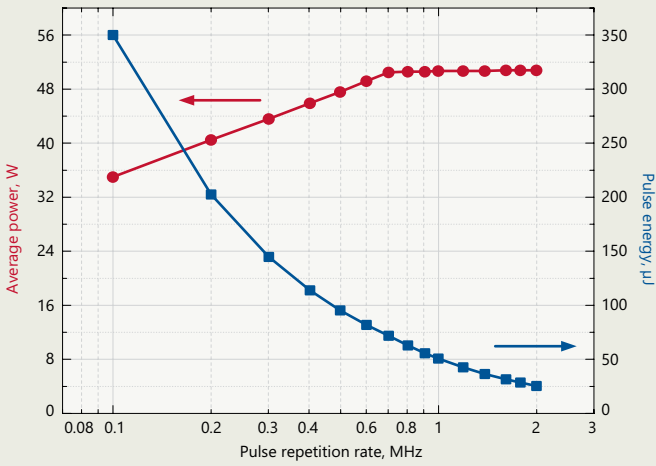

Fig 1. Typical dependence of output power and pulse energy of FemtoLux 50 laser at 1030 nm on pulse repetition rate

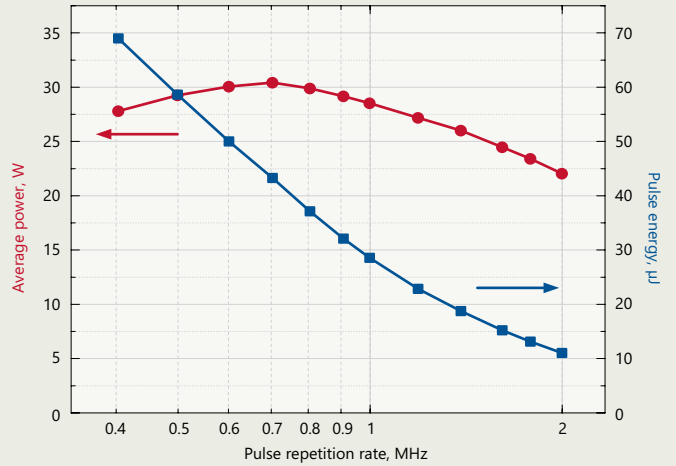

Fig 2. Typical dependence of output power and pulse energy of FemtoLux 50 laser at 515 nm on pulse repetition rate

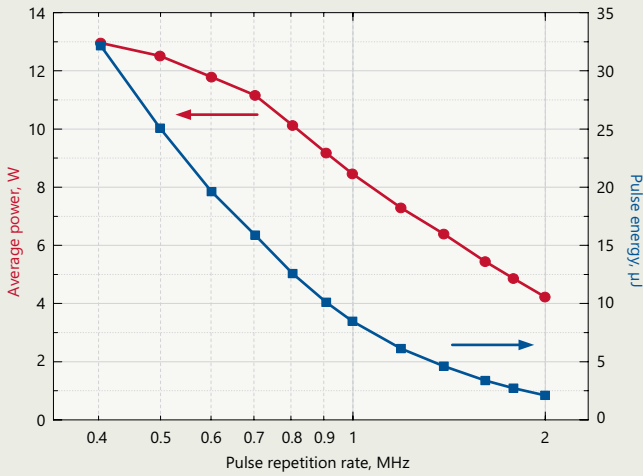

Fig 3. Typical dependence of output power and pulse energy of FemtoLux 50 laser at 343 nm on pulse repetition rate

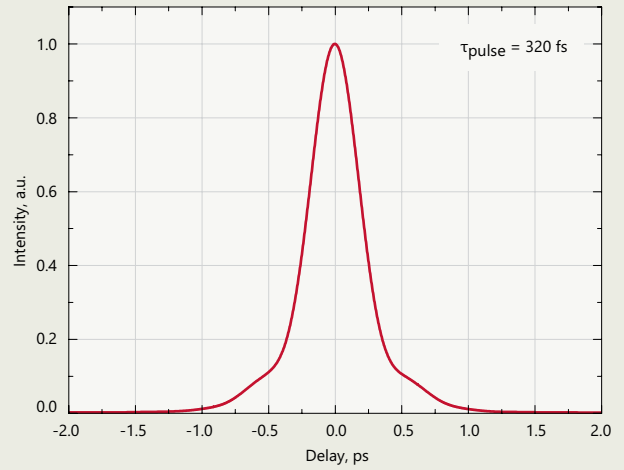

Fig 4. Typical FemtoLux 50 laser output pulse autocorrelation function at 1030 nm @ 1 MHz

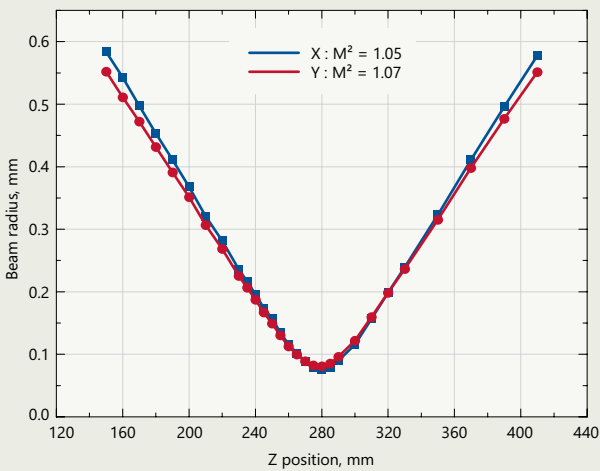

Fig 5. Typical M^2 measurement of FemtoLux 50 laser at 1030 nm

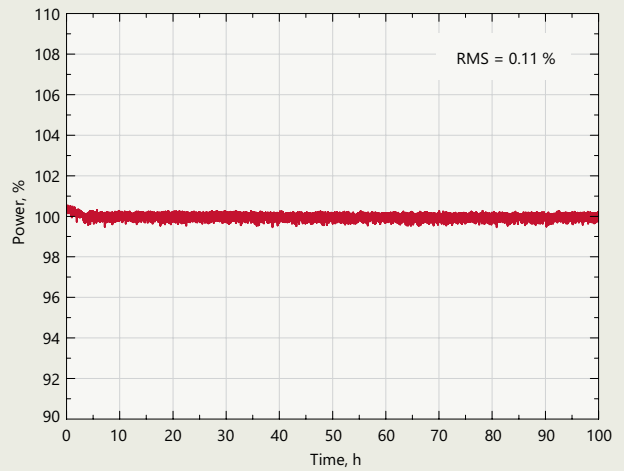

Fig 6. Typical long term average power stability of FemtoLux 50 laser at 1030 nm under constant environmental conditions

Performance of FemtoLux HE

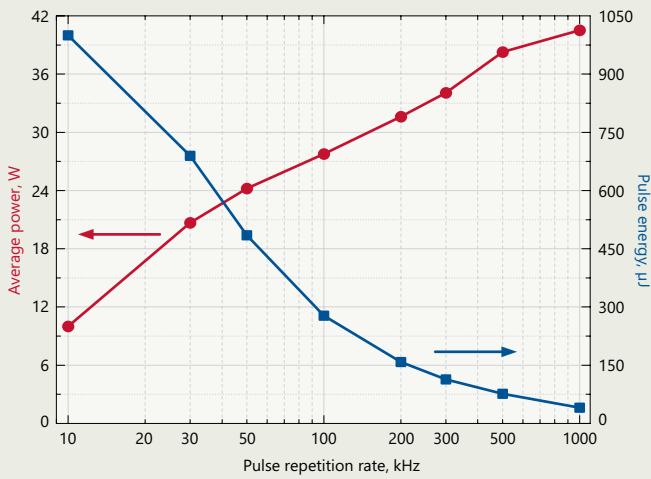

Fig 7. Typical dependence of output power and pulse energy of FemtoLux HE laser at 1030 nm on pulse repetition rate

Performance of FemtoLux 30

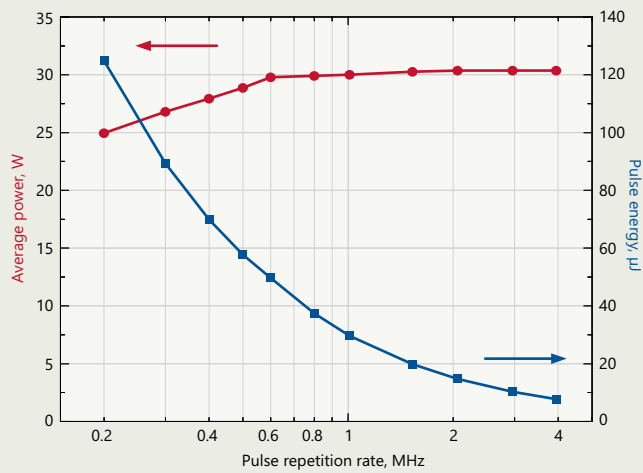

Fig 8. Typical dependence of output power and pulse energy of FemtoLux 30 laser at 1030 nm on pulse repetition rate

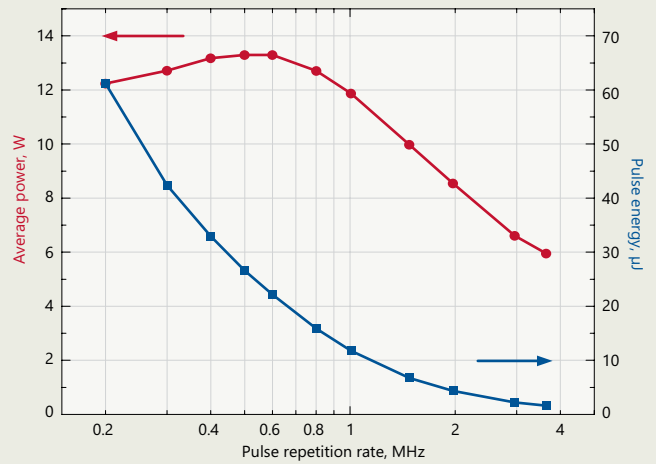

Fig 9. Typical dependence of output power and pulse energy of FemtoLux 30 laser at 515 nm on pulse repetition rate

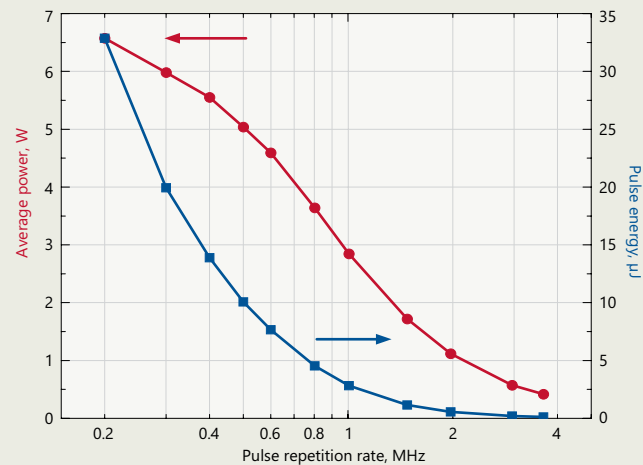

Fig 10. Typical dependence of output power and pulse energy of FemtoLux 30 laser at 343 nm on pulse repetition rate

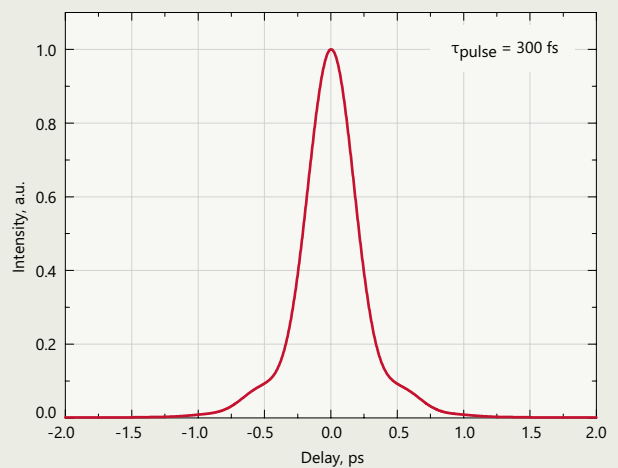

Fig 11. Typical FemtoLux 30 laser (at 1030 nm) output pulse autocorrelation function

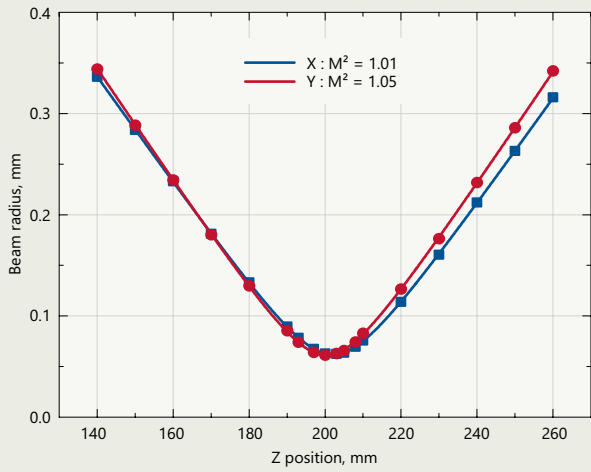

Fig 12. Typical M^2 measurement of FemtoLux 30 laser at 1030 nm

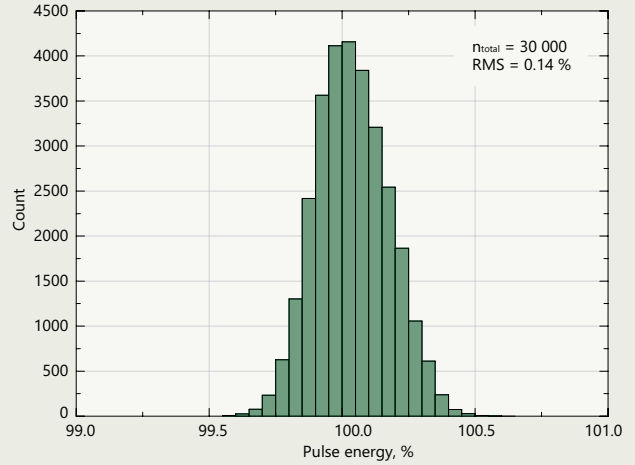

Fig 13. Typical pulse-to-pulse energy stability of FemtoLux 30 laser at 200 kHz over 30 000 pulses. RMS was calculated by using a set of mean values of 10 consecutive laser shots

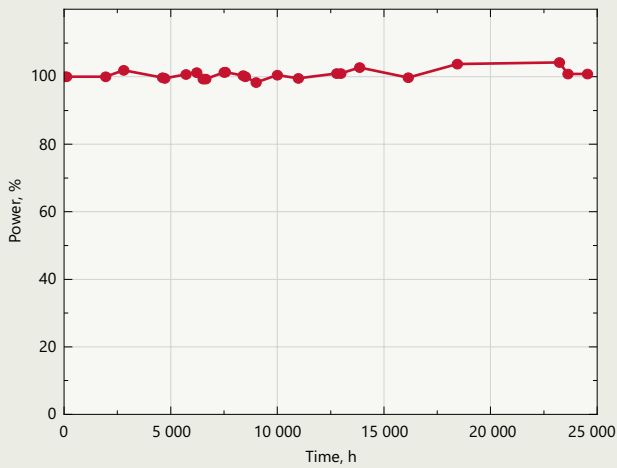

Fig 14. Long-term average power stability of the FemtoLux 30 laser at 1030 nm under constant environmental conditions over an extended duration of 25,000 hours

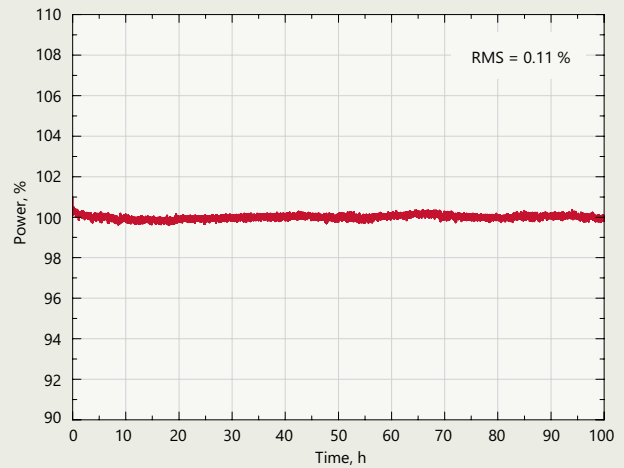

Fig 15. Typical long term average power stability of FemtoLux 30 laser at 1030 nm under constant environmental conditions

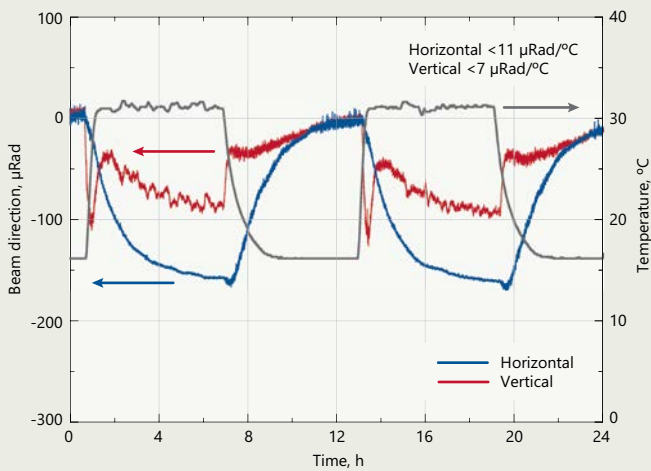

Fig 16. Typical beam direction stability of FemtoLux 30 under harsh environmental conditions

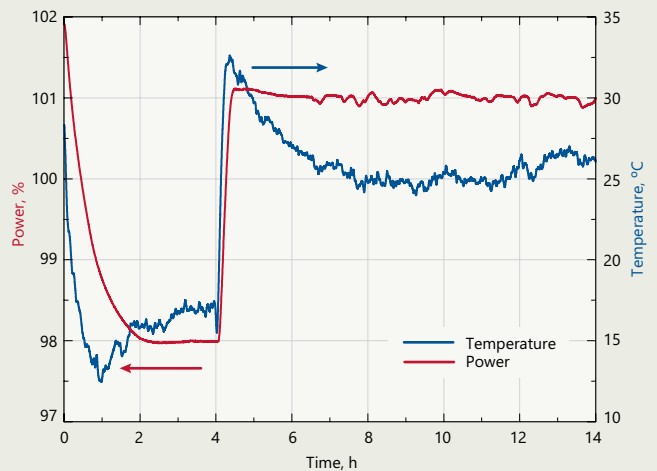

Fig 17. Average output power dependence of FemtoLux 30 laser on ambient temperature at 1030 nm

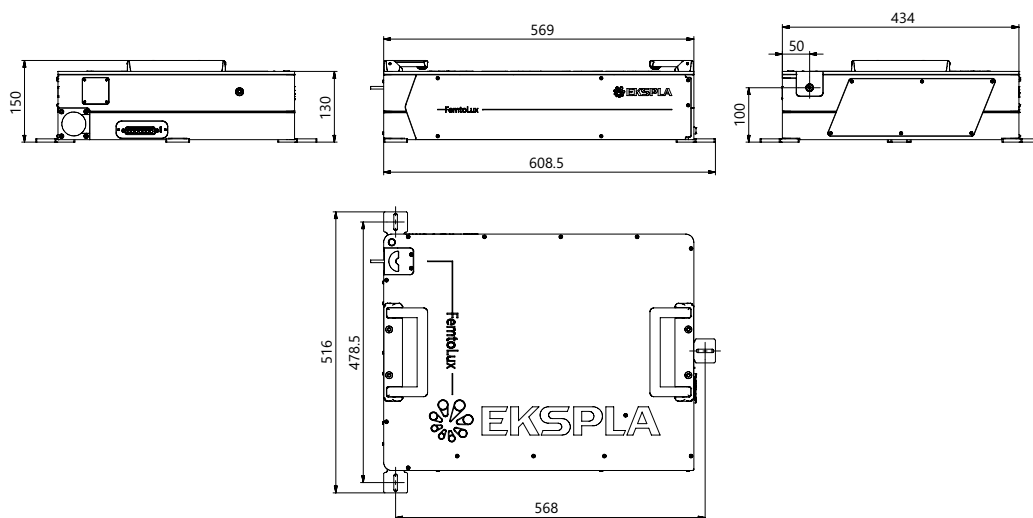

Fig 11. FemtoLux laser head outline drawing

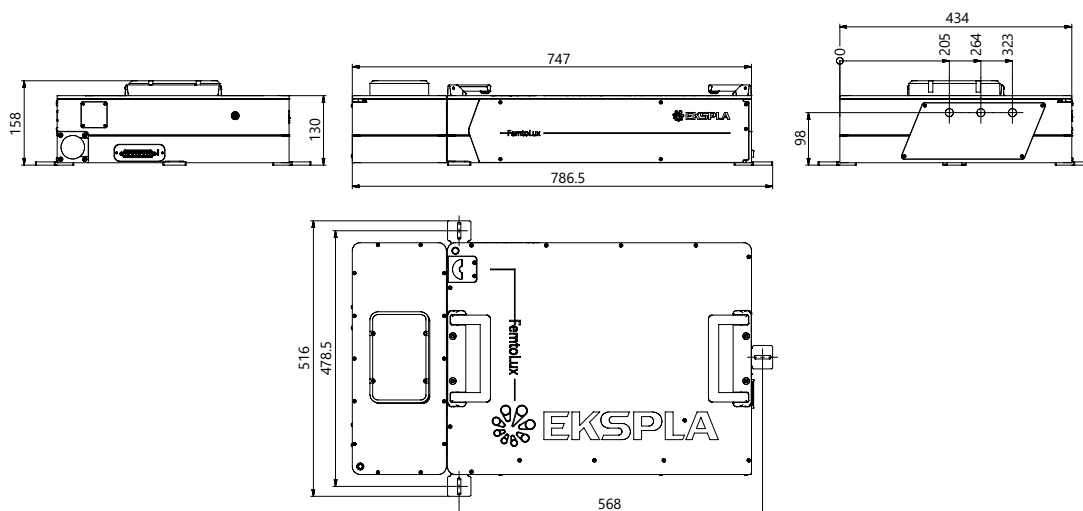

Fig 12. FemtoLux with harmonics module. Laser head outline drawing

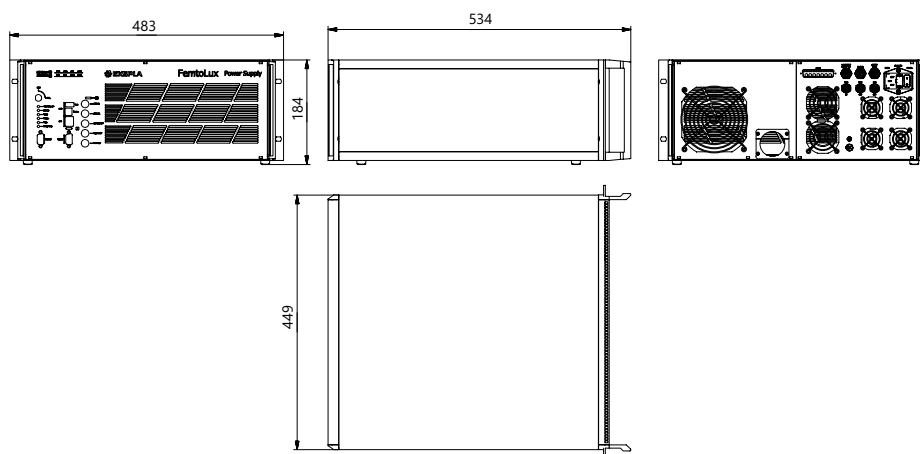

Fig 13. Power supply outline drawing

Laser control application

Ekspla Control Application is a software tool intended for day-to-day routine operation control. It is used to control the laser in API level through LAN or RS-232 communication types, the control capabilities are stored in the laser system itself, software is self-adaptive to the system, one application can be used with multiple systems and can run on different platforms – be it Windows, Linux or others using REST API commands.

